

RF Components

Directional Couplers

Shielded

HHM-24, 26 Series

FEATURES

- Compact, thin, and lightweight chip coupler manufactured in ceramic sheet multilayering process (L2.0×W1.25×T0.95mm/8mg).
- According with customers' circuits, wide characteristics are achieved from the low loss type(HM24 series) to the type with low pass function(HHM26 series).
- Provided with excellent environmental resistance and stable characteristics achieved under use of portable remote terminal in hostile environment.

APPLICATIONS

For 0.8 to 2GHz digital cellular and cordless phones

HHM24 SERIES

SHAPES AND DIMENSIONS/CIRCUIT DIAGRAM

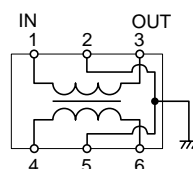
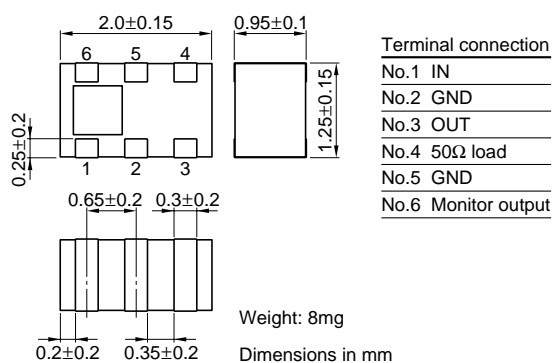

RECOMMENDED PC BOARD PATTERN

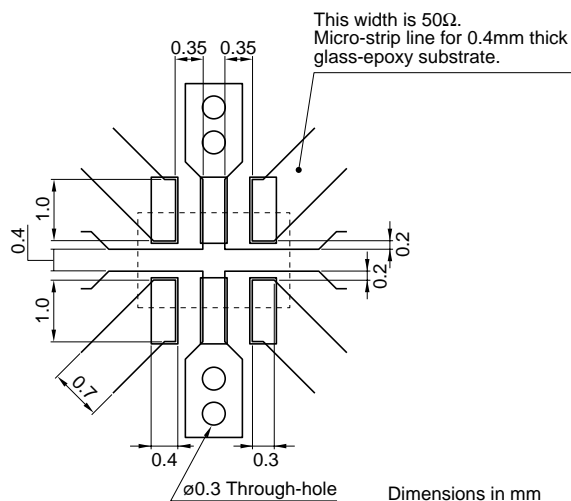

RECOMMENDED REFLOW SOLDERING CONDITIONS

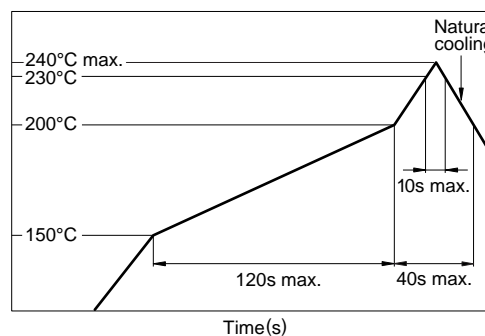

APPLICATIONS/TYPICAL ELECTRICAL CHARACTERISTICS

Part No.	Applications	Frequency f ₀ (MHz)	Insertion loss (dB)max.	Coupling factor (dB)typ.	Isolation (dB)min.	VSWR max.
HHM2405	GSM	880 to 915	0.25	-18	25	1.3
HHM2411	DCS	1710 to 1785	0.3	-15	20	1.4
HHM2412	PCS	1850 to 1910	0.35	-14.5	20	1.4

T_a=25±5°C

RF Components

Directional Couplers Shielded

HHM-24, 26 Series

HHM24 SERIES

TYPICAL ELECTRICAL CHARACTERISTICS

FREQUENCY CHARACTERISTICS

GMS HHM2405

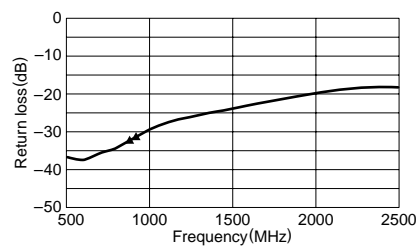
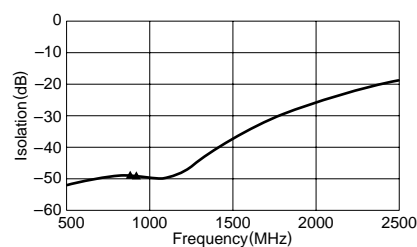
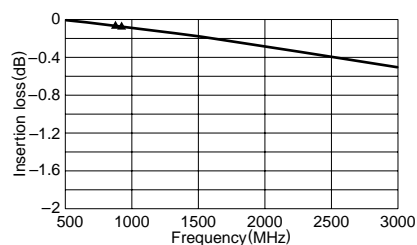
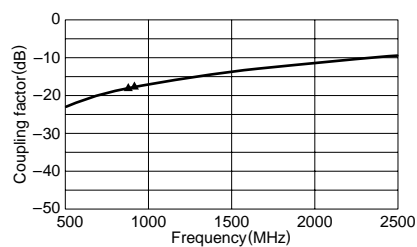

DCS HHM2411

PCS HHM2412

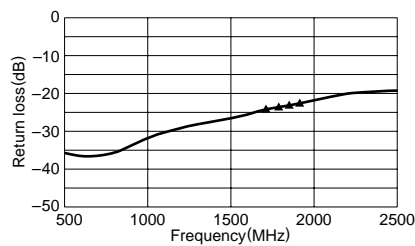
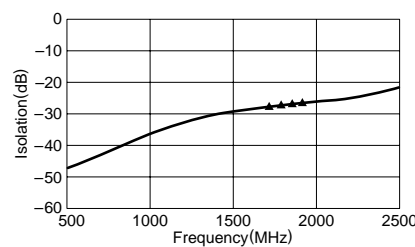
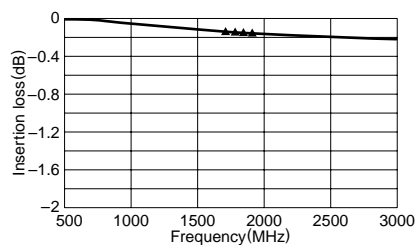
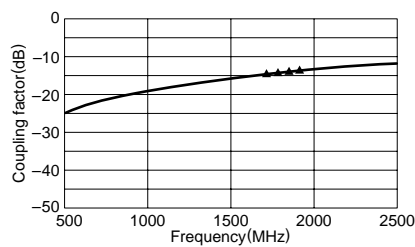

RF Components

Directional Couplers

Shielded

HHM-24, 26 Series

HHM26 SERIES

SHAPES AND DIMENSIONS/CIRCUIT DIAGRAM

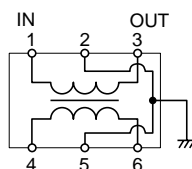
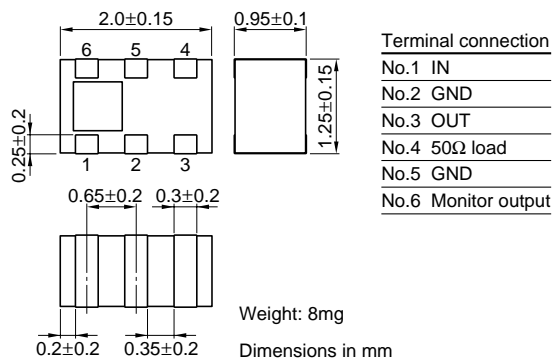

RECOMMENDED PC BOARD PATTERN

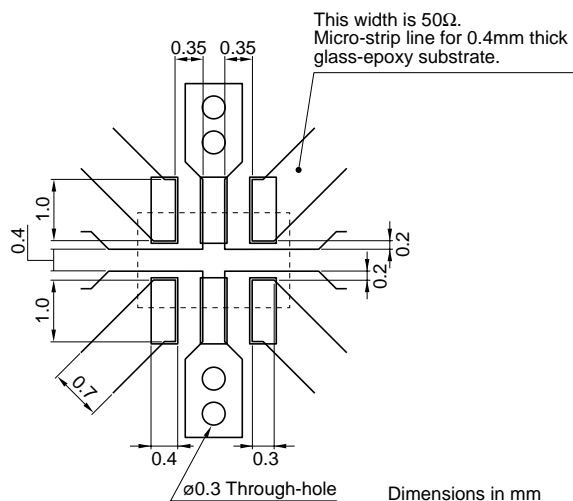

RECOMMENDED REFLOW SOLDERING CONDITIONS

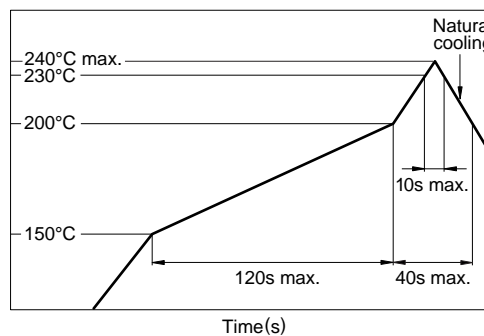

APPLICATIONS/TYPICAL ELECTRICAL CHARACTERISTICS

Ta=25±5°C

Part No.	Applications	Frequency fo(MHz)	Insertion loss (dB)max.	Coupling factor (dB)typ.	Isolation (dB)min.	VSWR max.	2fo attenuation (dB)min.*1	3fo attenuation (dB)min.*2
HHM2610	GSM	880 to 915	0.5	-14	22	1.5	22	14
HHM2607	DCS	1710 to 1785	0.5	-15	22	1.7	22	14

*1 2fo=Second harmonics out of band rejection

*2 3fo=Third harmonics out of band rejection

RF Components

Directional Couplers Shielded

HHM-24, 26 Series

HHM26 SERIES

TYPICAL ELECTRICAL CHARACTERISTICS

FREQUENCY CHARACTERISTICS

GSM HHM2610

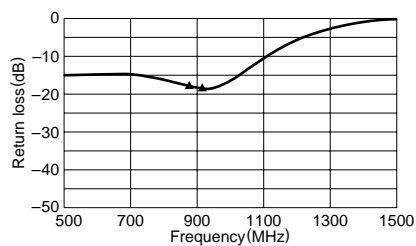
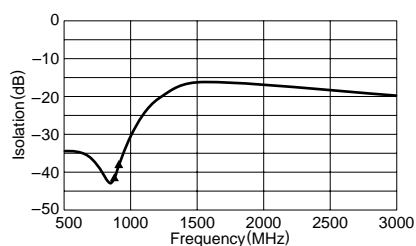
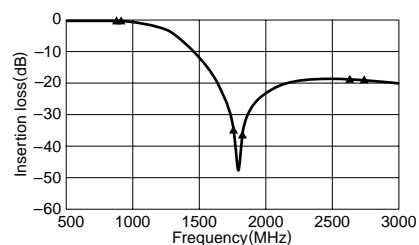
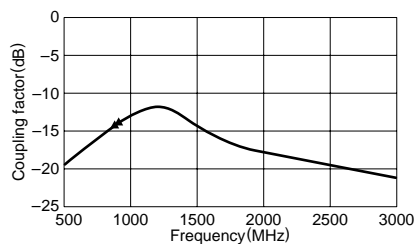

DCS HHM2607

